

SL8000

Continuous motion shrink-sleeve application system

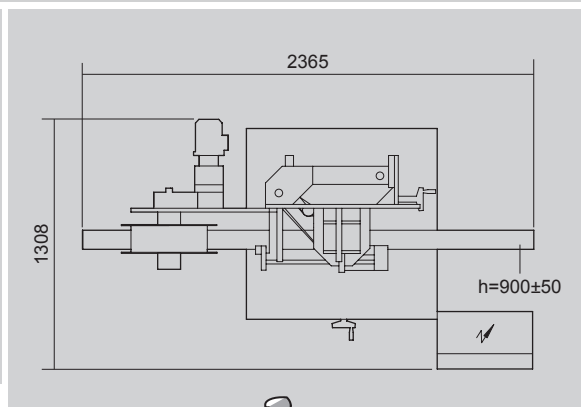
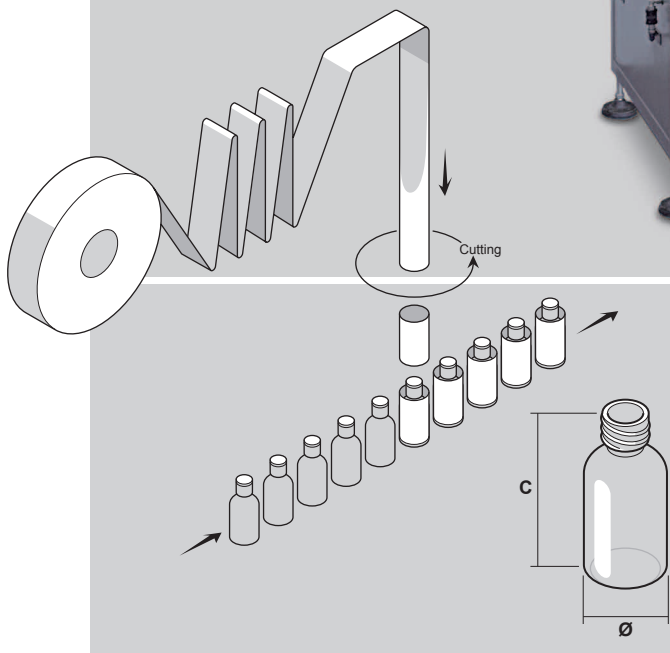

TECHNICAL DATA

Mechanical speed	STROKES/1'	170
Power absorption	KW	2,5
Size range	min.	max.
Ø	25	100
c	40	300

